

# The AD Drain Mount

The AD Drain Mount allows for installation of a permanent sampling tube without monopolizing the drain port. The sampling tube is bent or positioned to reach the active zone, ensuring the sample is taken away from the bottom or side sediment. The AD includes a quick connect with the option to add a level gauge, bottom sediment & water sight glass.

- Combines sampling with draining or filtration features from one port
- Able to get a clean, accurate sample from the active zone
- Provides a clean permanent drain or filter cart connection
- **Sampling range 0 - 125 psi (0 - 0.86 MPa)**

## Visual Oil Analysis Options

### Brass/Glass Level Gauge [Pictured]

- Glass level provides 120° viewing
- Available in 3", 6", 9" and 12" lengths

### Acrylic Level Gauge

- Acrylic vertical levels provide 360° view
- Minimizes the risk of breakage
- Available in 3", 6", 9" and 12" lengths

### Bottom Sediment & Water (BSW) [Pictured]

- Visually inspect and monitor the rate of accumulation of water, or sediment

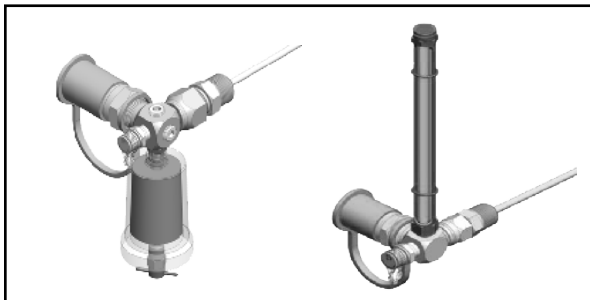
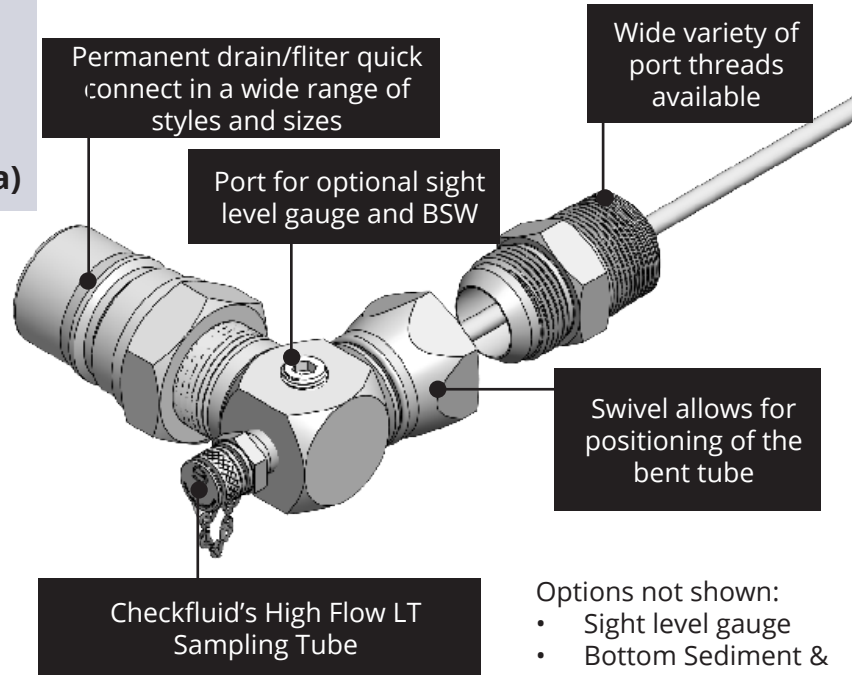

Part Number	Port	Port Adapter Size	Quick Connect Size	Plugged Port	Tube Length	Tube OD	Tube Material
AD16-16N	Drain	1" NPTF	1" ISO B	Yes	12"	1/4"	Stainless Steel
AD12-12N	Drain	3/4" NPTF	3/4" ISO B	Yes	12"	1/4"	Stainless Steel

**Note:** Contact for more information and pricing on breathers, sight levels, gauges, BSW etc  
Available in a variety of sampling tube lengths and port sizes



## AD Drain Mount Accessories

### Oil Level Gauges

What it does:

- Allows you to monitor the oil level in your machine
- Maintaining the correct level is essential as oil lubricates, cools and protects the moving parts of your machine
- Side or top installation available
- Vent kit option available for connection to the AB. This provides a completely enclosed system, preventing outside contaminants from entering the system



Part #	Description
GL9S	9" Brass Oil Sight, No Vent Kit, Side Mount, 1/2" OD Glass
GL9	Level Gage, 9", 1/4" - 18 NPT, Brass, 1/2" OD Glass
GLV9S	9" Brass Oil Sight w/ Vent Kit, Side Mount

3", 6", 12" sizes, and acrylic options also available

### Bottom Sediment & Water Bowl

What it does:

- Visually inspect for dirty oil, water contamination or excessive wear debris
- It is UV resistant
- It is extremely durable - the inherently strong polyamide material will withstand the toughest environments
- Allows free water to be easily drained from the system

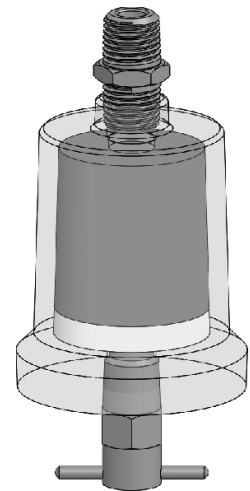

Part #	Description
COSG1X250	Oil Sight Glass (Bottom Sediment & Water Glass), 1 oz, 1/4" NPT
COSG3X250	Oil Sight Glass (Bottom Sediment & Water Glass), 3 oz, 1/4" NPT

**Note:** Contact for more information and pricing on breathers, sight levels, gauges, BSW etc

