

LT Sampling Instructions

Sample Preparation

1. Run equipment for approximately 30 minutes to get the oil hot
2. Record all data and identification on forms & attach labels to bottle
3. Pull the tubing out of the bag, keeping the zip seal partially closed. Remaining tubing should remain in coil for next use

Use caution in the vicinity of operating equipment. Use gloves and eye protection. Skin contact or inhalation can cause irritations

Standard Sample Method

- Insert tube end into the probe barb and insert the other end into the vacuum pump and bottle
- Tighten knob snug
- Ensure the tube extends into the bottle

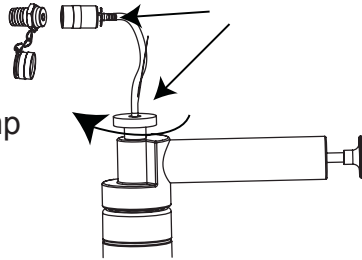

- Thread probe to valve.
- Pull back on the handle to draw the purge sample
- Purge volumes vary according to length and diameter

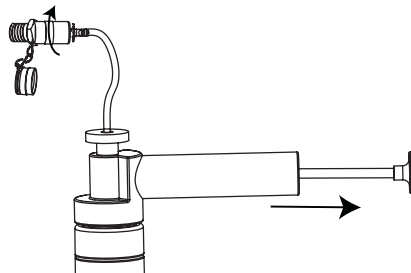

- Unthread the probe, 2 turns only, this will close the valve
- Remove purge bottle and thread on a new clean sample bottle
- **Repeat above steps to take sample**

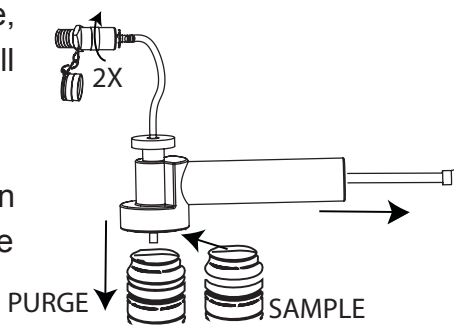

Extra Clean Sample Method

- To avoid air borne contamination, remove cap inside a sealed zip bag and create a drum like membrane
- Thread the bottle onto the vacuum pump and sample
- After sampling replace the cap inside the bag before removing

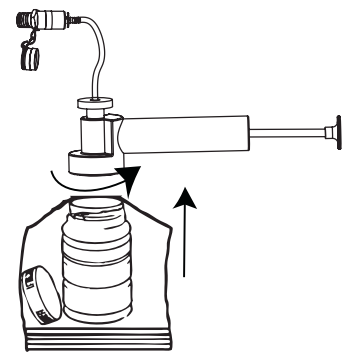

Sample Completion

- Responsibly dispose of the plastic tubing, bags, and purge oil
- Send the bottle **as soon as possible** to the appropriate lab for analysis

Quick Purge Rule:

- 1/4" OD tube = 2x length in cc (e.g. 12" = 24 cc)
- 5/16" OD tube = 3x length in cc (e.g. 12" = 36 cc)
- 3/16" OD tube = 1x length in cc (e.g. 12" = 12 cc)

