



B SERIES :

Non Pressurized Fluid Sampling Instructions

✓ PREPARE

Tools Required:

- Vacuum Pump (VAC)
- Sampling Probe (SBF4)
- 16 oz. Purge Bottle (L-16) or 4 oz (LC)
- Length of 1/4" OD Tubing (SER4)
- Sample Bottle (LC)

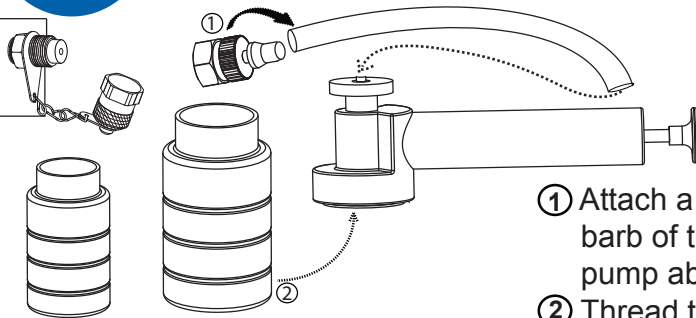

- ① Attach a length of new disposable tubing and insert onto barb of the probe. Place the other end into the vacuum pump about 1/2" into the bottle. Tighten the knurled nut.
- ② Thread the purge bottle onto the vacuum pump.

✓ CONNECT

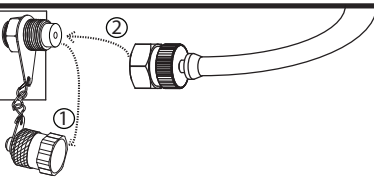

- ① Remove the metal cap on the B/BT valve and ensure the valve face is clean.
- ② Thread the probe onto the sampling valve.

✓ PURGE

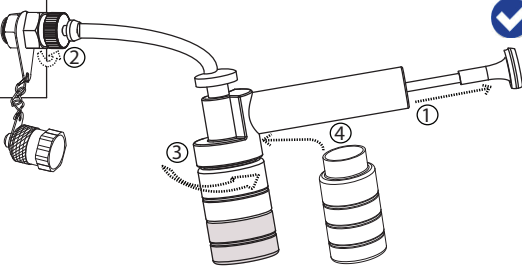

- ① Pull the handle back several strokes to draw 0.4 oz/12ml of fluid into the purge bottle for sampling tubes up to 24"/610mm. Call for recommended purge volumes on remote hose installations and tube lengths longer than 24".
- ② Unthread the probe only two threads to stop the flow.
- ③ Remove the purge bottle from the vacuum pump.
- ④ Replace with a new, clean sample bottle.

✓ SAMPLE

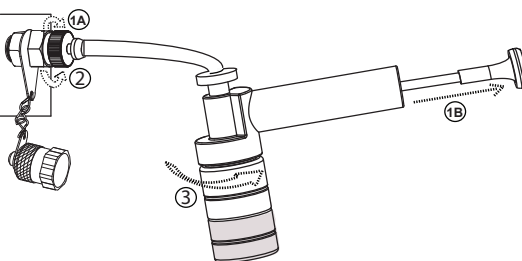

- ①A Rethread the probe onto the valve and ①B draw 3 oz/90ml of fluid to the fill mark.
- ② Unthread the probe two turns to stop the flow and suction the line clear of fluid or loosen the bottle..
- ③ Remove the bottle in a zip bag or in an area free from contamination.

✓ DISPOSE

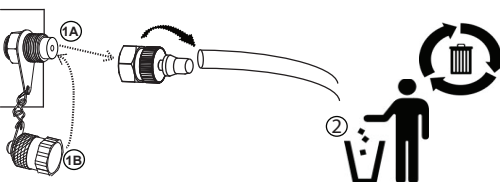

- ①A Unthread the probe completely and ①B recap the sampling valve.
- ② Dispose of the plastic tubing and purge oil responsibly. An extra zip bag can hold tubing and purge oil bottle.

✓ SEND

- Complete the paperwork and send the bottle as soon as possible to the lab to reduce the risk if action is required.



sales@checkfluid.com
www.checkfluid.com

Checkfluid Inc.
Toll Free: 1-866-652-8728
Fax: 519-652-0392